

Why Choose Rexnord?

When it comes to providing highly engineered products that improve productivity and efficiency for industrial applications worldwide, Rexnord is the most reliable in the industry. Commitment to customer satisfaction and superior value extend across every business function.

Delivering Lowest Total Cost of Ownership

The highest quality products are designed to help prevent equipment downtime and increase productivity and dependable operation.

Valuable Expertise

An extensive product offering is accompanied by global sales specialists, customer service and maintenance support teams, available anytime.

Solutions to Enhance Ease of Doing Business

Commitment to operational excellence ensures the right products at the right place at the right time.

Thomas XTSR Couplings



Rexnord Corporation

Rexnord is a growth-oriented, multi-platform industrial company with leading market shares and highly trusted brands that serve a diverse array of global end markets.

Process and Motion Control

The Rexnord Process and Motion Control platform designs, manufactures, markets and services specified, highly engineered mechanical components used within complex systems where our customers' reliability requirements and the cost of failure or downtime are extremely high.

Water Management

The Rexnord Water Management platform designs, procures, manufactures and markets products that provide and enhance water quality, safety, flow control and conservation.



XTSR52

XTSR71

Compact Size, Powerful Performance

Thomas XTSR couplings offer enhanced features, providing the highest value solution for rotating equipment.



Advancing the Industry

For decades, the reliability of Thomas Series 52 and 71 couplings have led the industry as the most highly specified disc coupling by rotating equipment engineers around the globe. Committed to evolving with our customers and their needs, Rexnord has advanced the Thomas Series 52 and 71 couplings. The new Thomas XTSR52 and XTSR71 disc couplings offer new and improved features optimized for customer installation, maintenance, operation and safety.

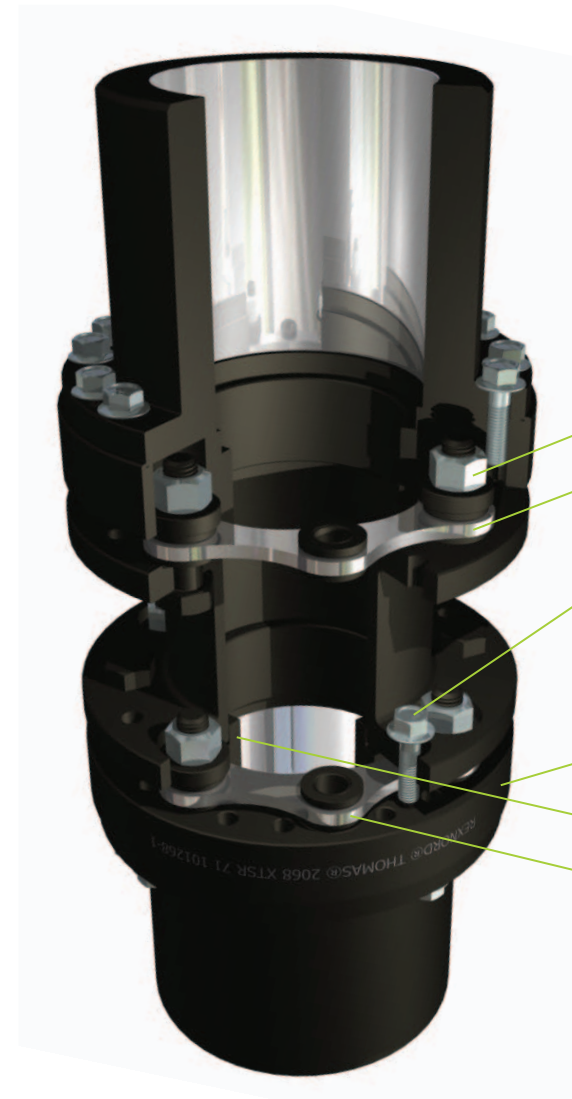

Optimized for the Industry

- **Higher Torque, Lower Mass:** Couplings are optimized for both NEMA/IEC and non-NEMA/IEC drivers
- **All Metric Design:** Globally-accepted units for tools and designs
- **Industry Compliant:** API 671/ISO 10441 (when specified), API 610/ISO 13709, ISO 14691, ATEX II 2GD c T6

Installation & Maintenance

- **Tapered Bolts:** Quick bolt installation without damaged disc packs
- **Unitized Disc Pack:** Quick and easy replacement with the elimination of loose parts
- **Integrated Balancing Hardware:** Innovative center member design to balance the coupling without special hardware
- **Modular Components:** XTSR52 and XTSR71 share disc packs and hardware components for convenient, lower cost inventory management
- **Retrofits to Thomas and John Crane Metastream Hubs:** Compatible with older technologies
- **Clear Product Markings:** Highly visible markings make re-ordering easy

Operations & Safety

- **Anti-Flail Ring:** Confines center member in the event of component failure
- **Overload Bushings:** Limits stress during startup to extend disc pack life
- **Standard Manganese Phosphate Coating:** Enhanced corrosion protection over popular black oxide
- **Optional Torque Overload Protection System:** Protects connected equipment during the occurrence of a torque spike

Innovative Coupling Solutions to Reduce Total Cost of Ownership

Count on Rexnord's superior product and service quality, expertise, and technical support to prevent costly maintenance, repairs and shutdowns, maximizing return over the coupling's total lifecycle.

To see how the proprietary and standard design features of Thomas XTSR couplings specifically help to deliver lower total cost of ownership, see the table below. The table provides points of consideration and potential savings when evaluating coupling total cost of ownership.

Design Feature	Delivered Benefit	Typical Quantified Benefit
Lighter coupling	<ul style="list-style-type: none"> Reduces wear on bearings and seals Reduces potential for unbalance 	\$7,800*
Component modularity	<ul style="list-style-type: none"> Reduces inventory of parts such as disc packs, drive bolts and washers 	\$1,200**
Torque overload protection system	<ul style="list-style-type: none"> Low cost, high reliability system protection Replace-in-place design, no hub removal or special equipment required 	\$5,500***
Standard Manganese Phosphate protection	<ul style="list-style-type: none"> Prevents corrosion 	\$200****
Total Savings		\$14,700

* Financial calculation based on 1/5 increased bearing life of an average \$375 U.S.- priced bearing + 3 hours to change bearing at \$75 per hour rate + 3 hours non-production time at a rate of \$2,500 per hour.

** Standard cost of inventory reduced by 66% on a typical inventory value of \$3,600.00.

*** Cost of savings of new center member element vs. special shear pins (avg. price of \$400) + 2 hours to change element at a \$75 per hour rate + 2 hours non-production time at a rate of \$2,500 per hour.

**** \$12.50 U.S.-priced paint or corrosion protection material + 2 1/2 hours to prep and coat.

The Highest Torque Capacity

The new Thomas XTSR designs coupled with Rexnord manufacturing processes and materials have resulted in some of the highest torque capacities in the industry. For a given bore size, the Thomas XTSR designs clearly outpace the competition on rated torque.

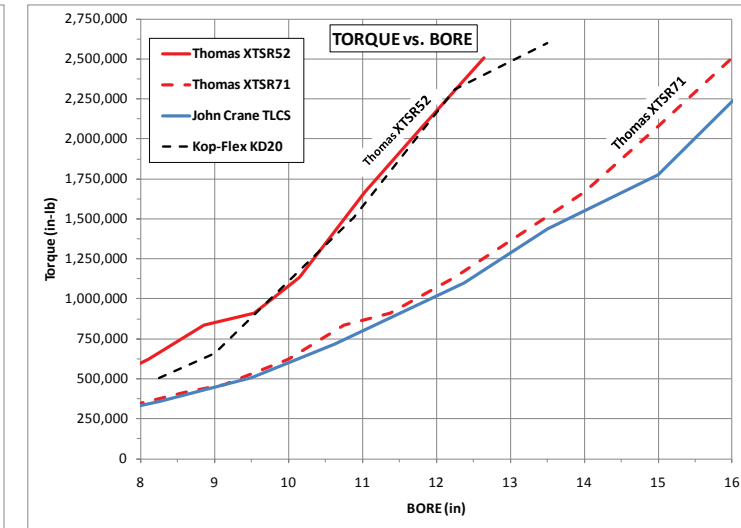
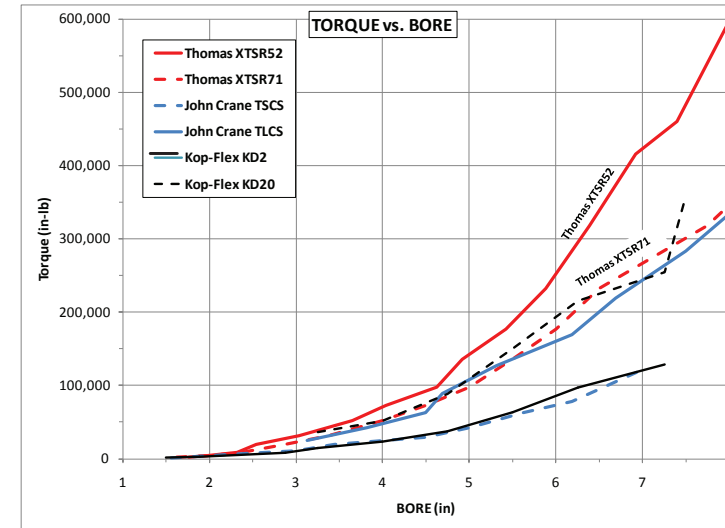

Optimized For NEMA/IEC Applications

Rexnord engineers targeted common torque and bore requirements when designing the new Thomas XTSR couplings. The result is a family of products that minimize the coupling mass for a given application. Lower mass translates into less loading on system bearings and seals, as well as easier system balancing.

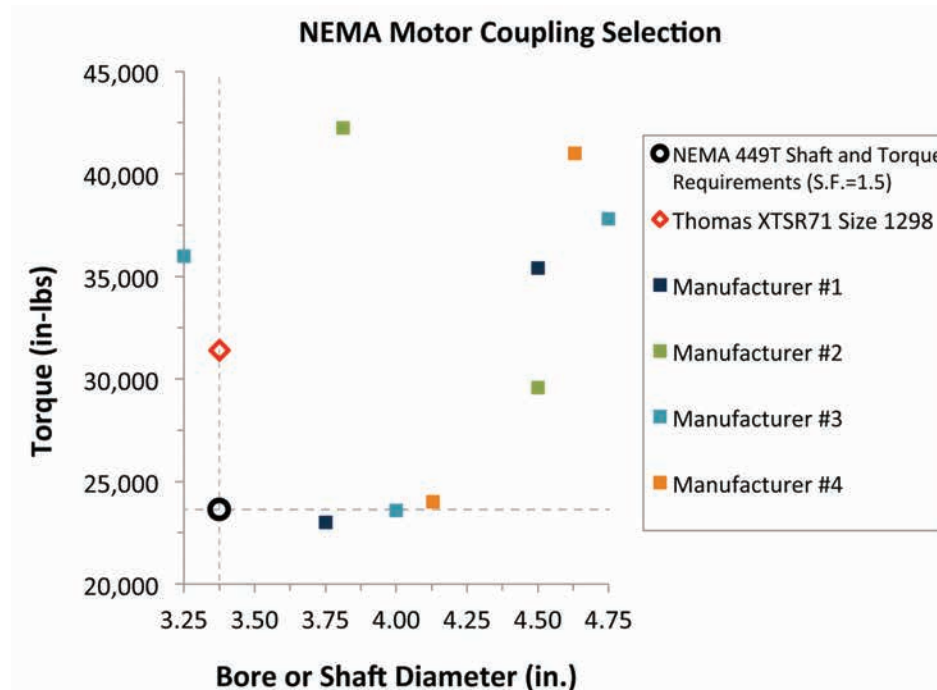

Disc Coupling Product Selector — Quick Access, Quick Selection

Search

Use the search function to enter specific information on the application.

STEP 2 of 2 Specifications back to environmental conditions >>

EQUIPMENT * required specifications

*Driver power: 55 HP
 *RPM: 1200
 Flywheel mounting required?
 yes no
 Driver bore size: 1.125 inches

Driven application: Pump - Centrifugal
 or
 *Service factor: 1
 Driven bore size: 1.125 inches

*Distance between shaft ends: 6 inches API Requirement: Not specified

Browse

Unsure of the application requirements? Use the browse function to narrow search and become familiar with product options.

Disc Couplings Products

Choose how to find your product **Browse By** Product Selector

Products Showing 2 of 2 products Page 1

Browse by

Max. Contin. Torque Ranges (in - lb)
 17,500 - 28,200

Distance Between Ends (inch)
 6.125 - 4.000 (2)
 10.001 - 14.000 (1)

API Requirement
 API 571
 API 510

Series XTSR71
 New product design replaces Series 71 & 71-8. XTSR71 is an adapter spacer coupling designed for ANSI, IEC, API and other pump applications. Can retrofit John Crane Metastream hubs.

54RDG Series
 Reduced diameter gear and grid replacement couplings used when overall shaft to shaft spacing is minimal.

[Series Details](#)
 Sizes: 1088

[Series Details](#)
 Sizes: 225

Results

Search results include drawings, data sheets and part numbers.

Disc Couplings Products

Choose how to find your product **Browse By** Product Selector

[back to browse >>](#)

Series XTSR71: Size 1088

XTSR71 couplings replace the Series 71 and 71-8 with upgraded features that include modular disc packs, improved torque ratings, reduced weight and ease-of-assembly features. Designed for applications requiring a spacer-type coupling such as ANSI, API and other process pumps. They are most commonly applied on motor, turbine, and gear driven pumps, compressors and blowers. XTSR71 can retrofit Thomas Series 71, 71-8 and John Crane Metastream hubs. The simple 3-piece design, fast drop-out center assembly, and dynamic balance characteristics compliment a disc design that allows for low flexing forces and high overload capacity.

[Request quote](#)

[Series Details](#)
[Email this product](#)

Specifications

Maximum Continuous Torque Rating: Up to 19,400 inch/lb
 Distance Between Shaft Ends Range: 3.700 to 12.070 inches
 Bore Capacity: 0.500 to 2.875 inches
 Maximum Operating Speed: 14000 rpm (balanced)

Rexnord — With You Every Step of the Way

Rexnord delivers the exact Thomas XTSR coupling solution you need, when you need it:

- **Quick quote turnaround** — 48-hour turnaround time for standard products.
- **Lead times** — Two-week lead time on standard products.
- **Emergency shipments** — 24-hour shipping for standard product components.

Why Choose Thomas Couplings?

Unsurpassed proven reliability and quality.

Thomas disc couplings are engineered for infinite life. Rexnord's experience and dedication to conservative design standards ensure maximum reliability on the most critical power train systems.

Longstanding industry experience.

Since 1914, Rexnord engineers have worked with customers to design and enhance Thomas disc coupling solutions. Rexnord works with customers to select and customize designs that are optimized for their specific applications.

Solutions-based product offering.

The Thomas coupling designs incorporate features optimized for motor, engine and turbine driven applications. For custom applications, Rexnord frequently works with customers to solve unique problem such as:

- Torsional tuning for variable frequency drives (VFD)
- Balancing for high speed applications
- Split hub mounting
- Electrically insulated couplings

To learn more about the XTSR Coupling offering, please contact us today:
 866-REXNORD (toll-free) or 414-643-2366 (outside the U.S.)

Or visit our website for more information including:

Online disc coupling product selector • Data sheets • Drawings • Brochures • Manuals • Technical white paper
www.rexnord.com/XTSR

